



460-IRD

(shown with optional shaker)

An easy and economical solution for a wide range of wood dust collection applications.

- Complete dust collection package includes fan, fan motor, push-button fan starter, bag filters and clear plastic dust disposal bags
- Fan provides high vacuum pressure with low operating sound levels for cleaner workplaces and lower sound levels
- Down flow air pattern allows airflow and gravity to move filtered dust to collection receptacles for longer bag filter life and reduced pressure drop
- Adjustable airflow baffles equalize dust dispersion to all collection receptacles, which minimizes emptying cycles
- Cageless filters and tool-free filter replacement reduce maintenance time
- Filtered air returning to interior workspace reduces HVAC costs
- Dura-Life™ "Twice the Life" bag filters provide longer bag life, which reduces maintenance costs and lowers pressure drop
- Optional automatic shaker is available for better collector performance
- Fans with higher static pressure are available for more demanding applications

OPERATIONAL EXPLANATION

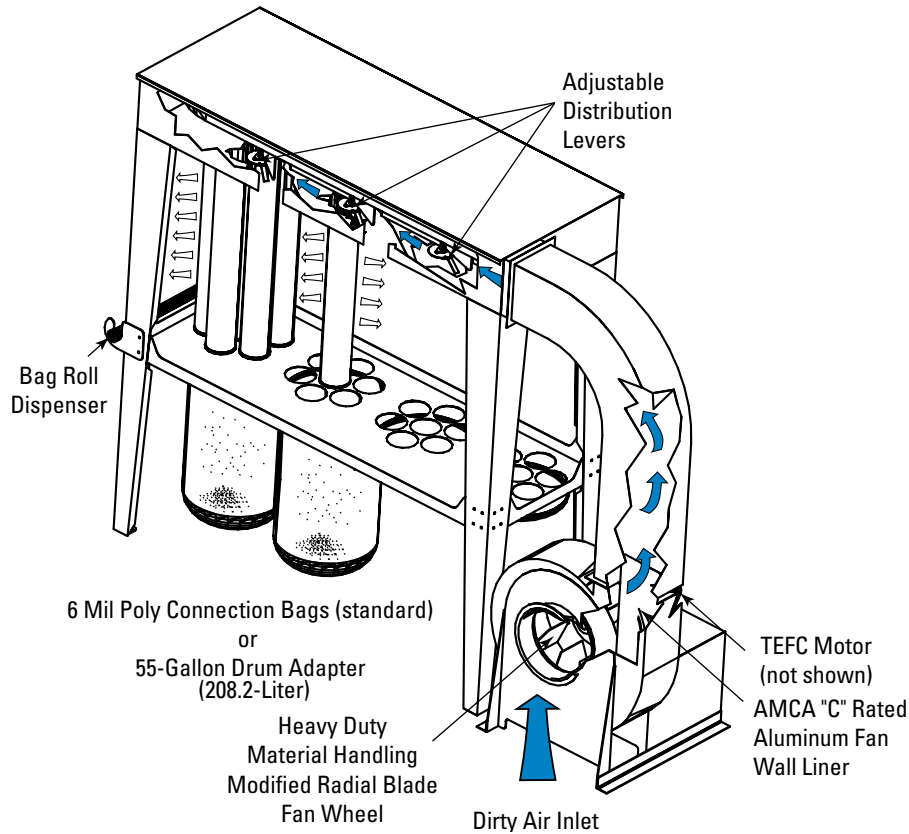

Dust laden air is pushed into the dirty air plenum by a high volume, high pressure heavy duty material handling fan. The dusty air is evenly distributed down inside of the high flow polyester bags which capture the dust and allow clean air to pass back into the work environment. Dust captured inside the bag is carried down into the dust receptacles at the bottom of the collector via gravity and airflow. An optional automatic shaker is available for even better collector performance.

Model	Fan (hp)	Air Volume / Static Pressure at Fan Inlet ("wg)*															
		6		7		8		9		10		11		12		13	
		cfm	m ³ /h	cfm	m ³ /h	cfm	m ³ /h	cfm	m ³ /h	cfm	m ³ /h	cfm	m ³ /h	cfm	m ³ /h	cfm	m ³ /h
260-IRD-5R**	5	—	—	—	—	—	—	—	—	1550	2633	1450†	2463†	1350	2293	1225	2081
260-IRD-7.5	7.5	3600	6115	2350	3992	—	—	—	—	—	—	—	—	—	—	—	—
360-IRD-7.5R	7.5	—	—	—	—	—	—	—	—	2175	3695	2025	3400	1850	3143	1650	2803
360-IRD-10	10	—	—	—	—	3700	6285	2850	4841	2125	3610	—	—	—	—	—	—
360-IRD-10R	10	—	—	—	—	—	—	—	—	2900	4926	2675	4544	2450	4162	2250	3822
360-IRD-15	15	—	—	—	—	4800	8154	4050	6880	2400	4077	—	—	—	—	—	—
460-IRD-15	15	—	—	—	—	4800	8154	4050	6880	2400	4077	—	—	—	—	—	—
460-IRD-15R	15	—	—	—	—	—	—	—	—	5050	8578	4350	7389	3900	6625	—	—
460-IRD-20	20	—	—	—	—	6875	11678	6375	10829	5875	9980	5325	9045	—	—	—	—

* Table data allows for 2 "wg collector loss with clean bag filters.

** Models with "R" at the end have higher static fans.

† Italic type is typical airflow applications.

DIMENSIONS & SPECIFICATIONS

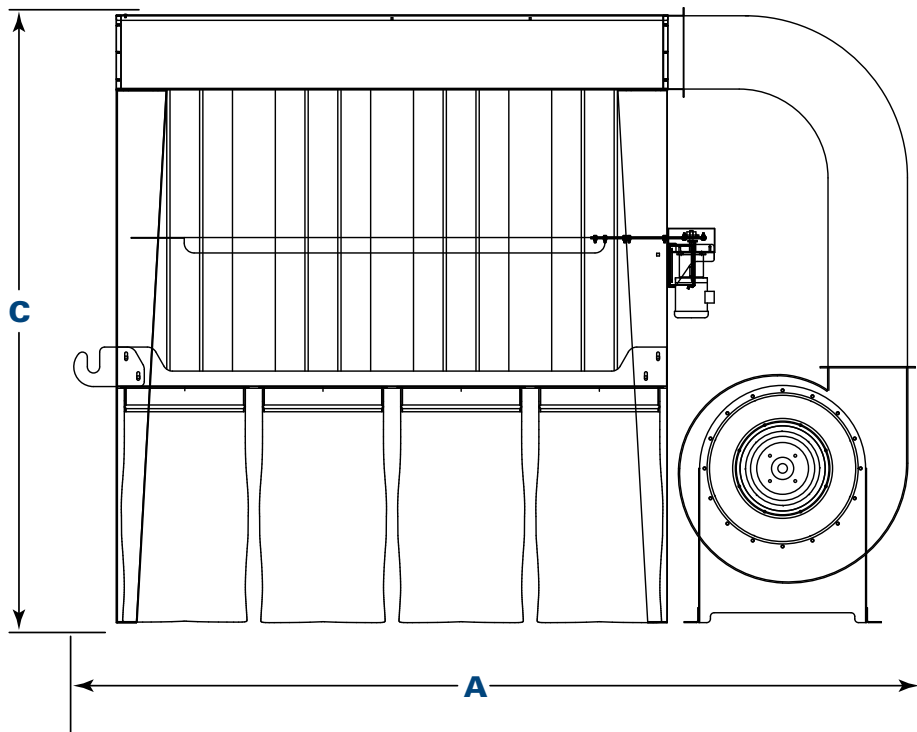

Model 460-IRD-20
(shown w/optional shaker motor)
Front View

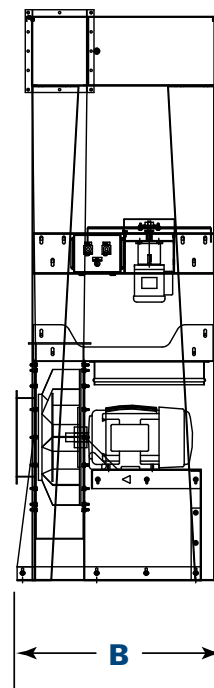

Model 460-IRD-20
Side View

Model	Nominal Airflow Range*		Cloth Area		No. of Bag Filters	No. of Dust Collection Receptacles	Dust Capacity w/ plastic bags		Motor (hp)
	cfm	m ³ /h	ft ²	m ²			ft ³	m ³	
260-IRD-5R**	1350 - 1450	2,293 - 2,463	128	11.9	14	2	20	0.6	5
260-IRD-7.5	2350 - 3600	3,992 - 6,115	128	11.9	14	2	20	0.6	7.5
360-IRD-7.5R	1850 - 2025	3,143 - 3,440	192	17.8	21	3	30	0.8	7.5
360-IRD-10	2850 - 3700	4,841 - 6,285	192	17.8	21	3	30	0.8	10
360-IRD-10R	2450 - 2675	4,162 - 4,544	192	17.8	21	3	30	0.8	10
360-IRD-15	4050 - 4800	6,880 - 8,154	192	17.8	21	3	30	0.8	15
460-IRD-15	4050 - 4800	6,880 - 8,154	257	23.9	28	4	40	1.1	15
460-IRD-15R	3900 - 4350	6,625 - 7,389	257	23.9	28	4	40	1.1	15
460-IRD-20	5875 - 6375	9,980 - 10,829	257	23.9	28	4	40	1.1	20

Model	Shipping Weight		Dimensions					
	lb	kg	A		B		C	
			in	mm	in	mm	in	mm
260-IRD-5R**	1100	499.0	96.4	2448.6	43.9	1115.1	124.6	3164.8
260-IRD-7.5	1360	616.9	104.1	2644.1	45.3	1150.6	124.6	3164.8
360-IRD-7.5R	1300	589.7	124.7	3167.4	43.9	1115.1	124.6	3164.8
360-IRD-10	1710	775.6	132.7	3370.6	44.4	1127.8	124.6	3164.8
360-IRD-10R	1350	612.3	124.1	3152.1	43.9	1115.1	124.6	3164.8
360-IRD-15	1890	857.3	137.1	3482.3	45.5	1155.7	124.6	3164.8
460-IRD-15	2070	938.9	165.1	4193.5	45.5	1155.7	124.6	3164.8
460-IRD-15R	2140	970.7	170.5	4330.7	45.1	1145.5	124.6	3164.8
460-IRD-20	2200	997.9	170.5	4330.7	45.3	1150.6	124.6	3164.8

* Table data allows for 2 "wg collector loss with clean bag filters.

** Models with "R" at the end have higher static fans.

STANDARD FEATURES & AVAILABLE OPTIONS

Collector Design	Std	Opt
Down Flow Design	X	
Airflow Balancing Baffles and Levers	X	
Cageless Filter Design	X	
Tool-Free Filter Removal	X	
Minimum 14-Gauge Carbon Steel Construction	X	
12 Gauge Carbon Steel Tubesheet	X	
Integral Dust Disposal Bag Storage Rack	X	
Direct Drive High Output Material Handling Fan	X	
AMCA "C" Rated Aluminum Fan Wall Liner	X	
230/460, 3 Phase TEFC NEMA Premium ^{®*} Efficient Motor	X	
Filter-to-Fan Transition	X	
1/3 HP Auto Shaker		X
Exterior Weather Kit		X
Bag Filters		
7 in (177.8 mm) Diameter x 60 in (1524 mm) Long Dura-Life™ Polyester Bag Filters	X	

Paint System	Std	Opt
Durable Industrial Finish	X	
Standard Colors: Torit Blue or Storm White	X	
Dust Collection Receptacles		
50 - 6 Mil Clear Plastic Disposal Bags with 10 Cubic Foot (0.3 m ³) Capacity	X	
Quick Opening Cam Clamps for Disposal Bag Change	X	
55-Gallon (208.2-Liter) Drum Adapters		X
Support Structure		
10 Gauge Carbon Steel Construction	X	
Electrical Controls, Gauges and Enclosures		
Push Button Magnetic Fan Starter in NEMA 1 Enclosure	X	
Shaker Controls in NEMA 4 Enclosure (comes with the following features) <ul style="list-style-type: none"> • Manual and Automatic Shake Switch • On-Time Automatic Shake Adjustment Dial • Off-Time Automatic Shake Adjustment Dial • 120 Volt Cord 		X
Warranty		
10-Year Warranty	X	

* All 60 Hz motors 1 HP and above are EISA compliant.
 NEMA Premium is a registered trademark of National Electrical Manufacturers Association.

Significantly improve the performance of your collector with genuine Donaldson Torit replacement filters and parts. **Call Donaldson Torit today 800-365-1331.**



Tel 800-365-1331 (USA)
 Tel 800-343-3639 (within Mexico)
donaldsontorit@donaldson.com
donaldsontorit.com
 Donaldson Company, Inc.
 Torit
 P.O. Box 1299
 Minneapolis, MN
 55440-1299 U.S.A.

EXACTLY WHAT YOU NEED.™

Data Sheet IRD Dust Collectors (06/12)
 © 2008 Donaldson Co., Inc. All Rights Reserved. All products, product specifications, and data (airflow, capacity, dimensions, or availability) are subject to change without notice, and may vary by region or country. Donaldson Torit is a registered trademark of Donaldson Company, Inc. Contains Donaldson proprietary technology.