

## Dryflo Mist Collectors

Series DMC-C and DMC-D1

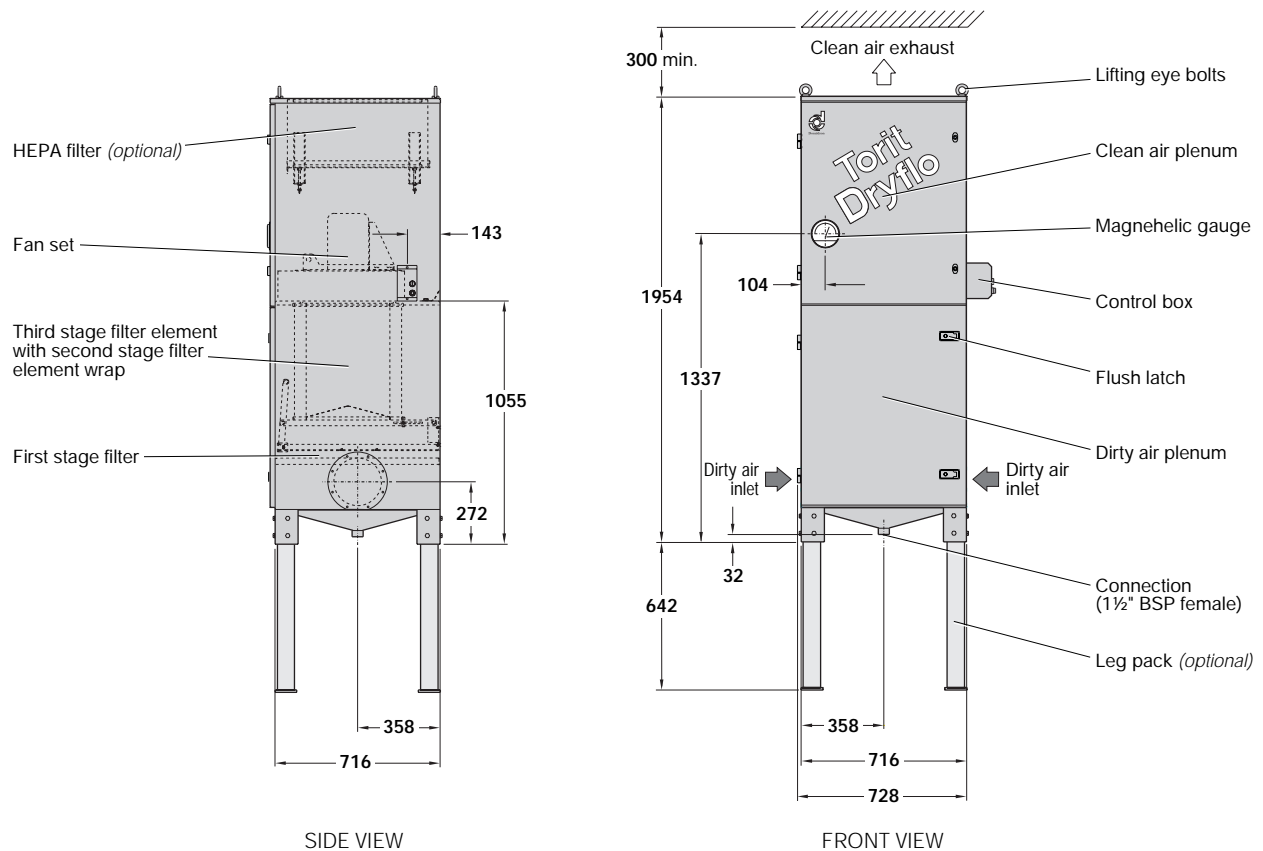

### Dryflo DMC-C mist collector

Model DMC-C with integrated HEPA filter illustrated

#### SPECIFICATIONS

Model	No. of filter elements*	Filtration area	No. of HEPA filters	Motor rating	Approx. net weight
DMC-C			0		260 kg
DMC-C with integrated HEPA filter	1	13m <sup>2</sup>	1	1.5 kW	279 kg

\*Refer to filter element specifications in table below

#### FILTER ELEMENT SPECIFICATIONS

A first stage filter and a second stage filter element wrap is included per third stage filter element. Dependant on the application, a different first stage filter can be selected:

- Wire mesh (standard)
- Thin screen (for heavy particle loading applications)
- Polypropylene (for heavy liquid loading applications)

## Dryflo Mist Collectors – Series DMC-C and DMC-D1

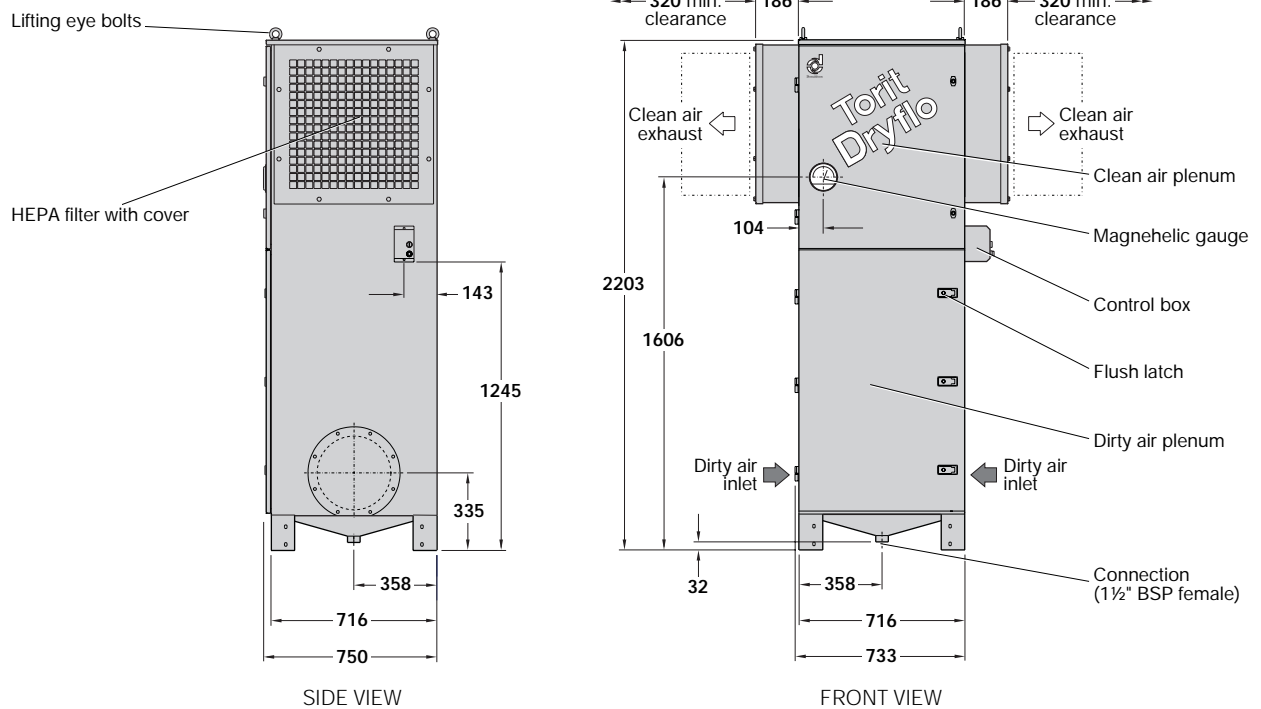
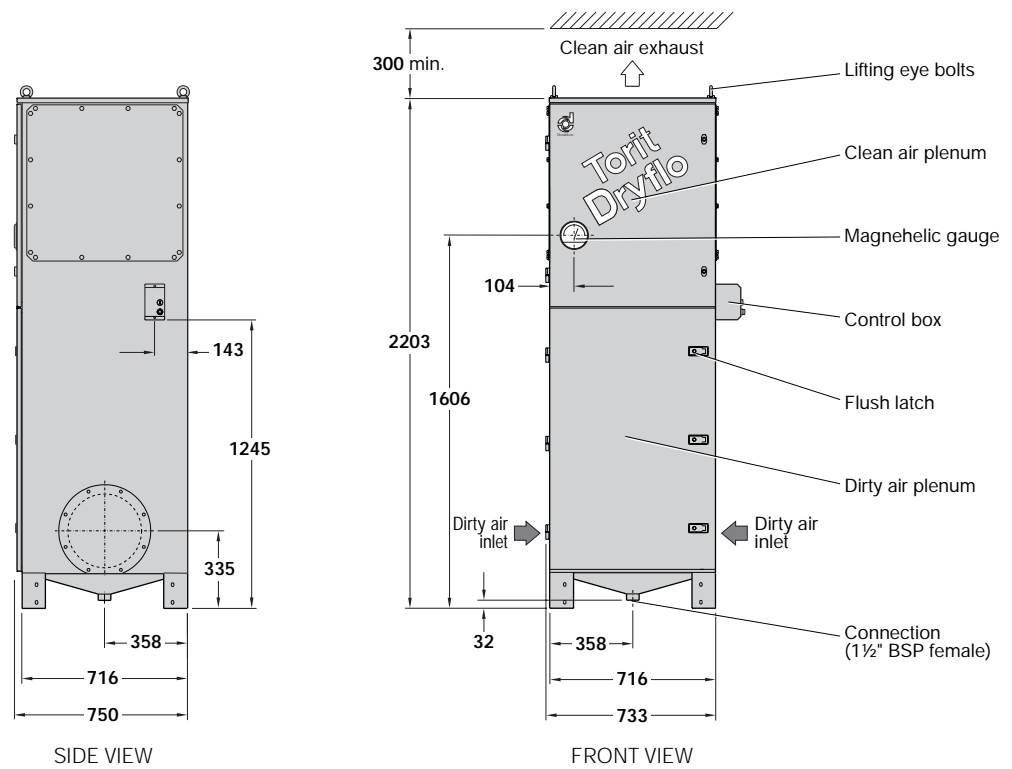

### Dryflo DMC-D1 mist collector

Models DMC-D1 and DMC-D1 with HEPA filter illustrated

#### SPECIFICATIONS

Model	No. of filter elements*	Filtration area	No. of HEPA filters	Motor rating	Approx. net weight
DMC-D1			0		353 kg
DMC-D1 with HEPA filter	1	20.4m <sup>2</sup>	2	2.2 kW	391 kg

\*Refer to filter element specifications on page 1

**DESIGN SPECIFICATIONS (standard equipment)**

**Operating temperature:** 5° to 60°C  
**Power supply:** 3 x 230V + Pe-50 Hz  
 3 x 400V + Pe-50 Hz  
**Finishing:** PU paint colour RAL 5019 (blue)

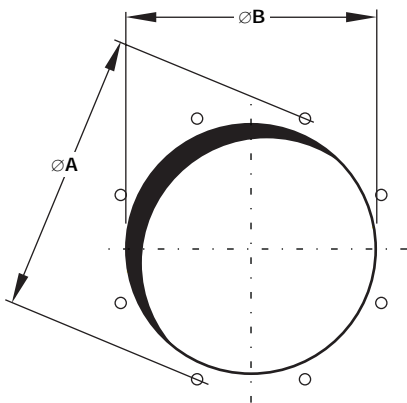

Model	DIMENSIONS in mm*			No. of holes (Ø11.5)
	Nominal Ø	ØA	ØB	
DMC-C	200	241	203	8
DMC-D1	315	366	318	8

\* DIN 24154/2 (July 1990)

**Inlet details for Dryflo DMC-C and DMC-D1**

**OPTIONS**

INLET PACK		
Transition flanges	DMC-C Inlet NW200	DMC-D1 Inlet NW315
NW100	✓	
NW125	✓	
NW160	✓*	
NW180	✓*	✓
NW200		✓
NW224		✓
NW250		✓
NW280		✓*

✓\* : includes transition flange with tube extension

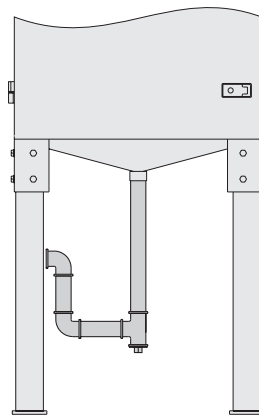

**P-trap**

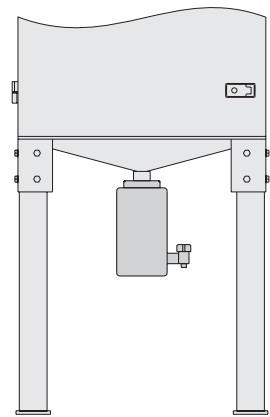

**Collection bottle**

- Leg pack
- Drain screen

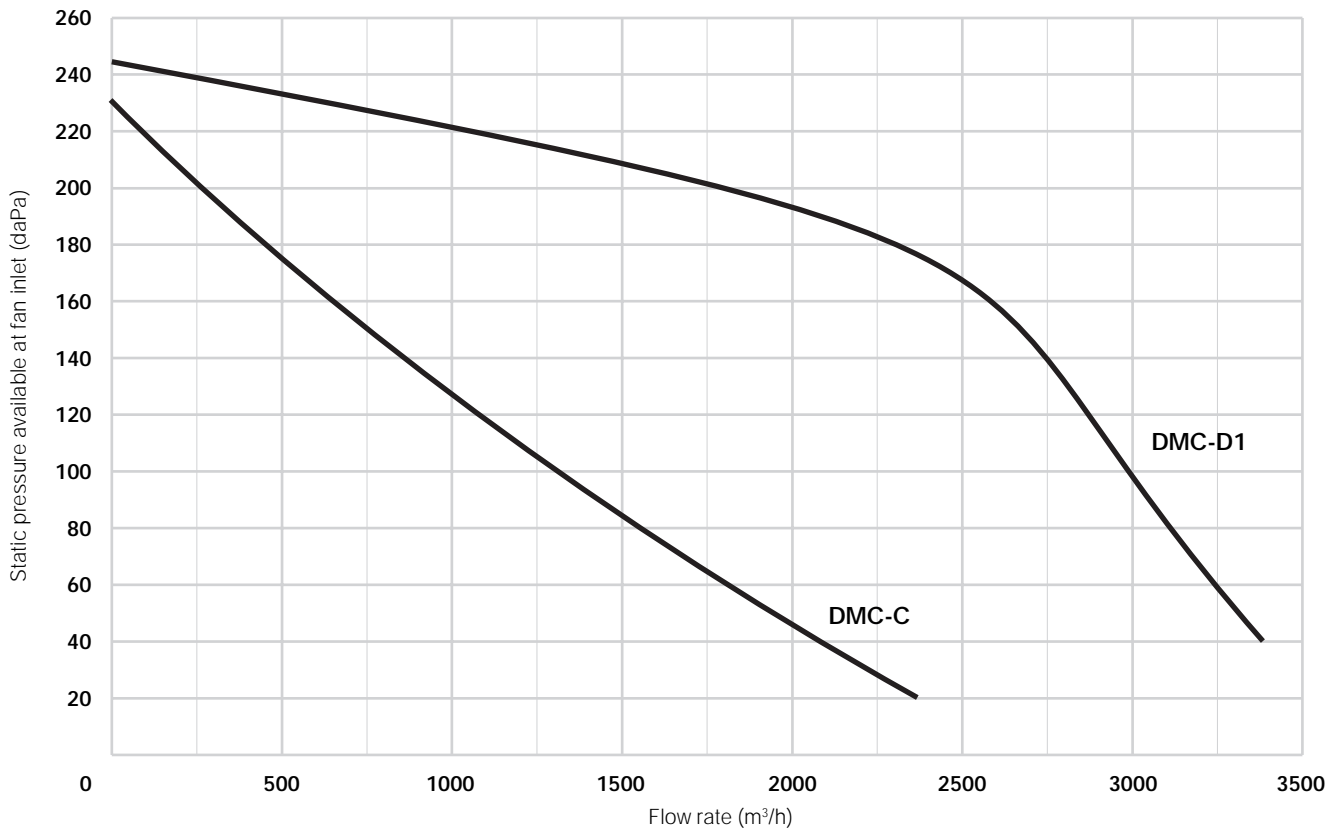

**Fan performance curves**

### FAN SELECTION

These curves indicate static pressure available at fan inlet for a given application, when fitted into a collector.

To select the most suitable fan for a given application:

- 1 Determine the air volume, in m³/h, needed to entrain the oil mist.
- 2 Estimate pressure drop through connected system – i.e. between point of entrainment and collector inlet.
- 3 Assess pressure drop over mist collector prior to replacing filter elements, usually 100 daPa.
- 4 The sum of **2** and **3** = static pressure at fan inlet.
- 5 Consult graph for fan performance available.

### FAN NOISE

	DMC-C	DMC-D1
<b>LpAeq*</b>	72 dB(A)	75 dB(A)

\* Measurement according to DIN 45635/1 at 1m distance, in semi-free field conditions, usual tolerance ±2 dB(A)

### FAN MOTOR SPECIFICATIONS

Voltage: 230V/400V for DMC-C  
400V/690V for DMC-D1

Cycle: 50 Hz

Speed: 2870 RPM

Insulation class: F

Protection class: IP55



www.toritdce.com  
www.donaldson.com

Humberstone Lane  
Thurmaston  
Leicester LE4 8HP  
England

Tel +44 (0)116 269 6161  
Fax +44 (0)116 269 3028

Email: toritdce.uk@mail.donaldson.com

Research Park Zone 1  
Interleuvenlaan 1  
B-3001 Leuven (Heverlee)  
Belgium

Tel +32 (0)16 383 970  
Fax +32 (0)16 383 938

Email: toritdce.be@mail.donaldson.com