

Modular Baghouse Dust Collectors

Now with

DURA-LIFE™
Twice The Life Filter Bags

Award-Winning
Filter Media



Modular Baghouse

Compact, Modular Design

The enhanced Donaldson® Torit® Modular Baghouse (MB) delivers reliable, efficient, continuous-duty, pulse-jet operation. The MB advantage is found in the breakthrough technology of Dura-Life™ filter bags. Dura-Life bags offer longer bag life and reduced emissions. When it does come time to replace the filter bags, Quick-Release Filter Bag Cages have been added to the collector to make replacing filter bags easier. The MB provides reliable service with easy maintenance. Computer designed inlets and deflector plates, coupled with maximized bag spacing, result in optimal airflow with minimal abrasion. Advanced valves, providing 50% more cleaning air, result in a more efficient operation. Over the life of the collector, no other baghouse can provide this much value.

MB Offers:

- **New models with high body inlets allow higher air-to-media ratios on lighter dusts**
- **New square models help minimize ducting and accessory costs**
- **Dura-Life "Twice the Life" Filter Bags**
- **Clean-air bag access for easier bag service**
- **Welded design increases durability**
- **Integral fan option reduces space requirements**
- **Tool-free installation of filter bags & cages**
- **10-year warranty**

*Efficient &
Reliable*
with
Dura-Life™
Twice The Life Filter Bags



405MBW10

Modular Baghouse

Operations & Features

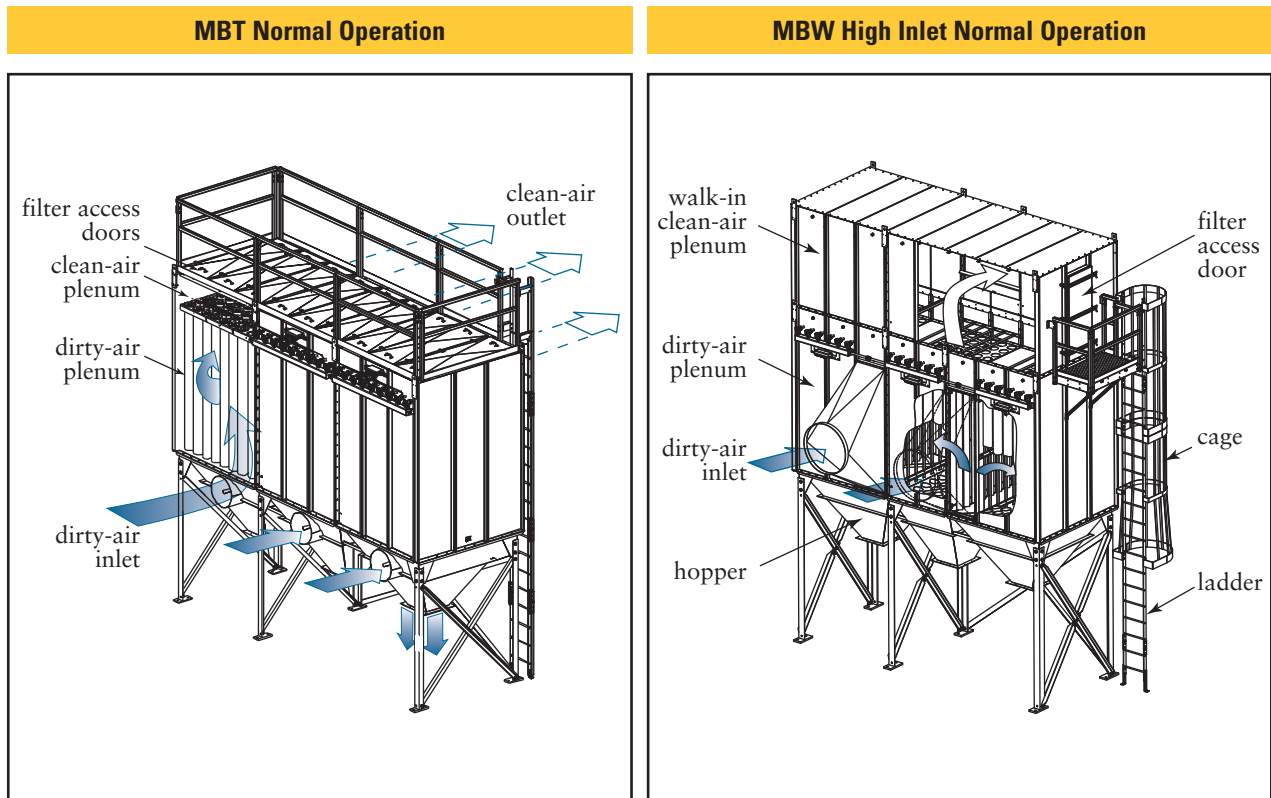

The Modular Baghouse collector comes in two models: the MBT allows walk-on, top access to the bags (clean-air side) of the collector. This configuration is ideal for indoor or tight budget applications. The MBW offers a walk-in clean-air plenum, so bags can be replaced in any kind of outdoor weather.

The MB has two inlet configurations; the most common configuration allows the dirty-air to enter through the hopper inlet located under the filter bags. The dirty air hits a deflector at the end of the inlet, which causes heavy particulate to fall directly into the hopper. This reduces the amount of dust that comes in contact with the bags resulting in longer bag life and lower pressure drop. For applications with light and fibrous dust, a high body inlet is available that reduces upward air velocities allowing the dust to properly fall into the hopper after the bags have been pulsed.

Donaldson®

Modular Baghouse

Engineered for Reliable Performance

Modular Baghouses are a reflection of Donaldson Torit's commitment to technical research and development. Sophisticated FLUENT®* computer airflow analysis has been used to assure the Modular Baghouse provides a uniform airflow resulting in reduced bag abrasion, longer bag life and lower maintenance costs.

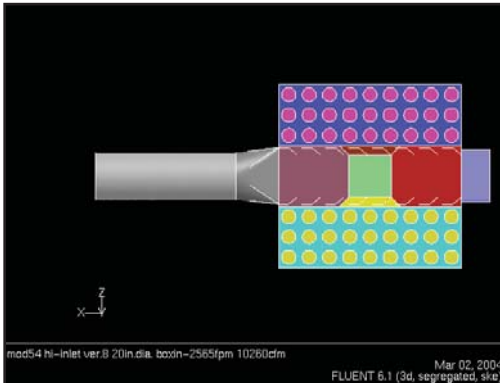

Top view of Modular Baghouse with high inlet without airflow.

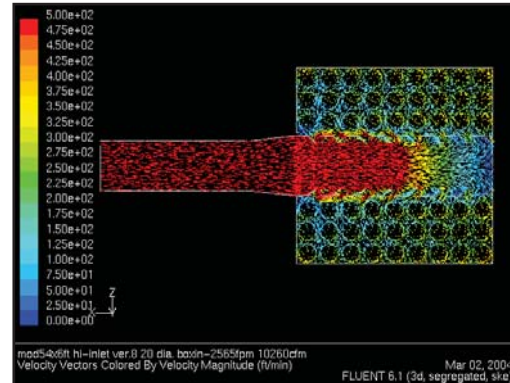

Top view of Modular Baghouse with high inlet showing FLUENT Computer Analysis of airflow.

FLUENT computer airflow analysis shows that the baffles in the MB high inlet deflect and reduce dust particle velocities and then properly distribute them throughout the collector for effective filtration with minimum bag and collector wear.

Easy Maintenance Quick-Release Filter Bag Cages (patent pending) make filter bag removal extremely easy. When swung into position, the handle serves as a lever to remove the cage from the tubesheet. The Quick-Release Filter Bag Cage requires only 6 pounds of force to remove compared to other cages that require 50 pounds.



* FLUENT is a registered trademark of Fluent, Inc.

Modular Baghouse

Proven Performance on Hundreds of Applications



405MBW10
at a foundry



324MBWS10
*at a shingle manufacturing facility
collecting sand*



54MBTH8
*at a cabinet shop on wood dust,
cutting, moulding and sanding*



162MBT8
on wood dust



324MBWS10
at a glass manufacturing facility



405MBT8
at brick manufacturing facility

Modular Baghouse

Dimensions & Specifications

MODEL 162MBT8 SHOWN

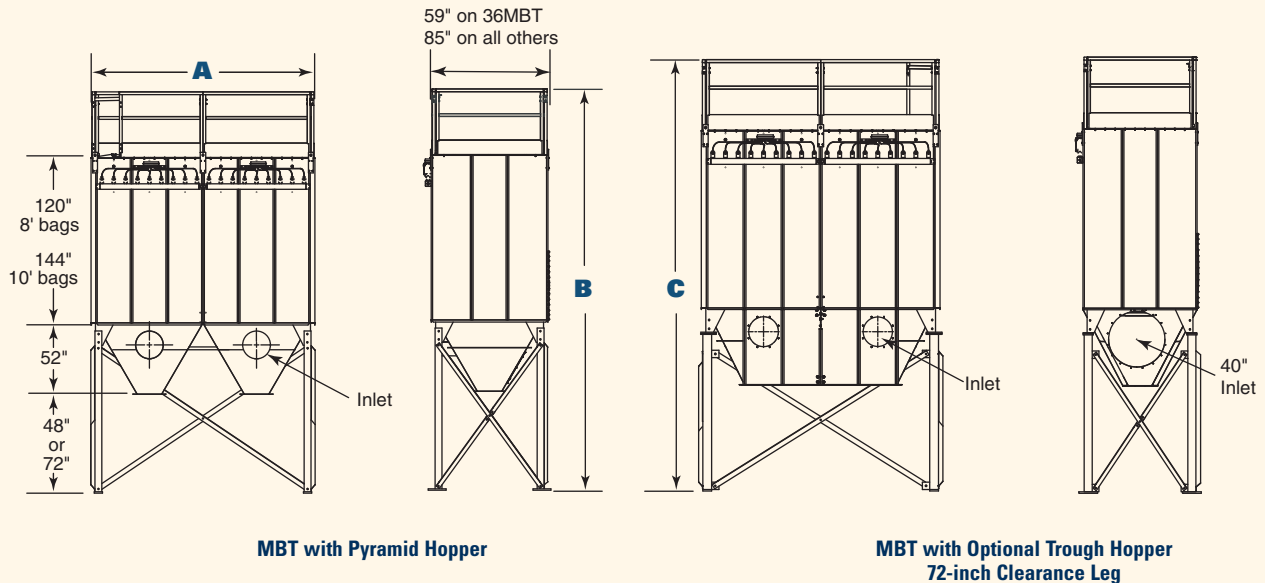

MODEL 162MBW8 SHOWN

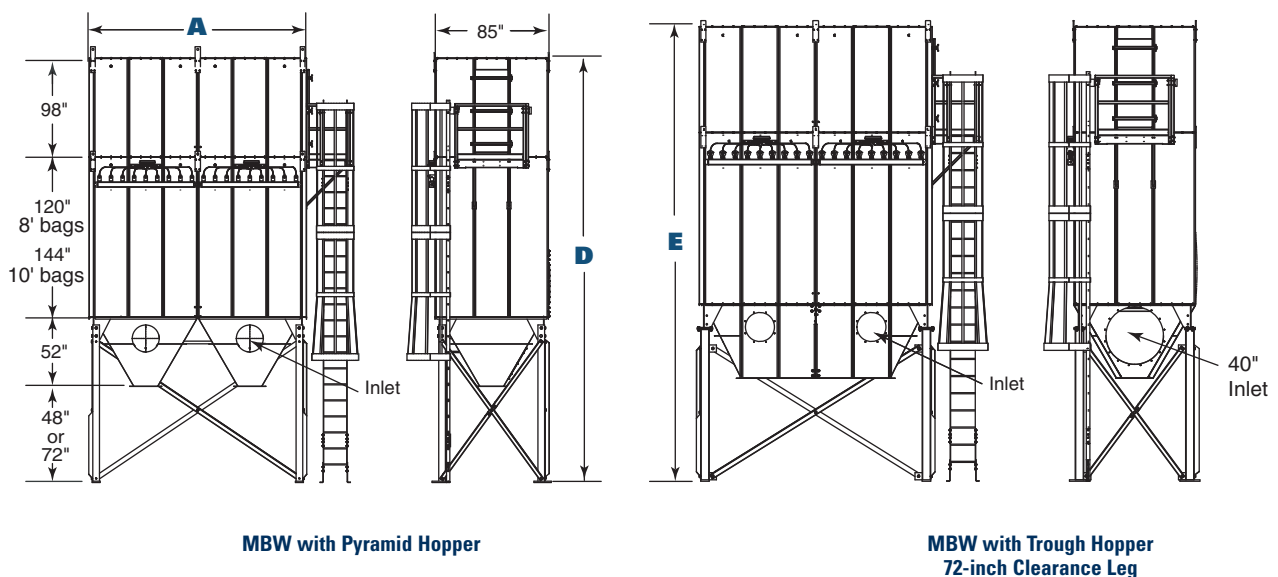

Modular Baghouse

Dimensions & Specifications

MODEL 162MBTH8 (Modular Baghouse High Inlet) SHOWN

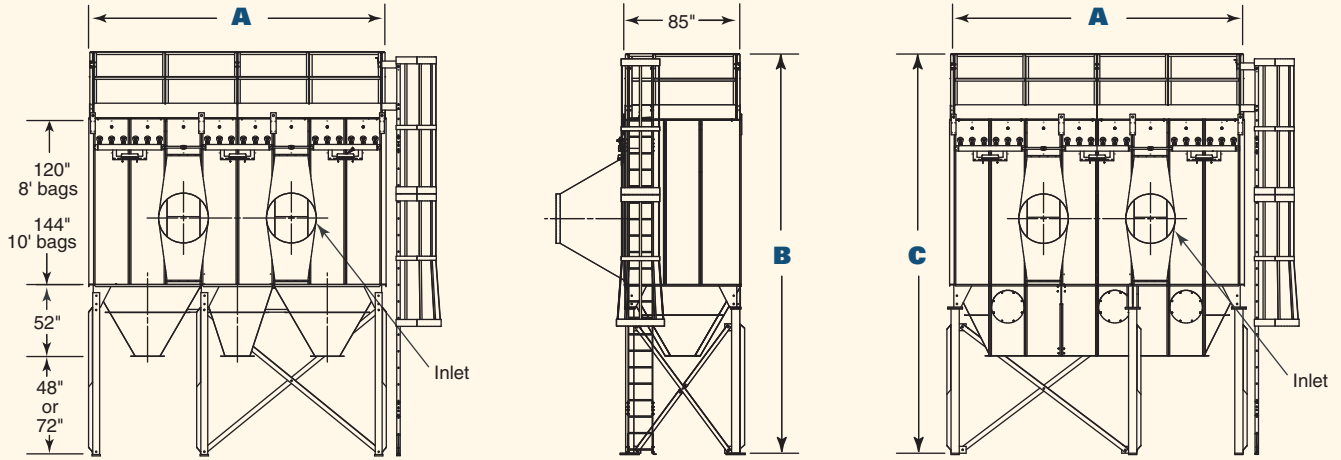

MBTH with Pyramid Hopper

MBTH with Trough Hopper

MODEL 162MBWS8 (Modular Baghouse Square) SHOWN

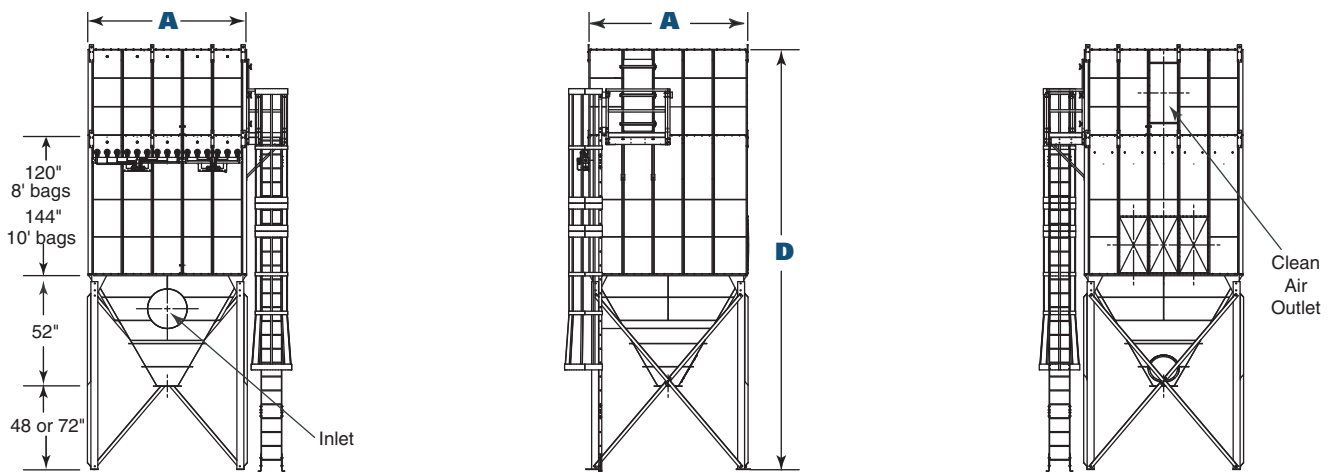

MBWS with Pyramid Hopper

MBWS with Pyramid Hopper
Side View

MBWS with Pyramid Hopper
Rear View

Modular Baghouse

Dimensions & Specifications

Model	Nominal Airflow Range* (cfm)	Cloth Area (ft ²)	No. of Bags	No. of Valves	Shipping Weight (lbs)	
					MBT	MBW
36 MBT5	1,150-2,880	288	36	6	2500	–
36 MBT6	1,380-3,450	345	36	6	2850	–
36 MBT8	1,840-4,600	460	36	6	3200	–
54 MBT6	2,070-5,180	518	54	6	3800	–
54 MBT8	2,760-6,910	691	54	6	4200	–
54 MBT10	3,460-8,660	866	54	6	5000	–
54 MBT(W)H8	2,760-8,290	691	54	6	5890	6870
54 MBT(W)H10	3,460-10,390	866	54	6	6565	7710
81 MBT(W)8	4,150-10,390	1039	81	9	3900	6100
81 MBT(W)10	5,190-12,990	1299	81	9	5509	7222
81 MBT(W)H8	4,150-12,460	1039	81	9	7085	8145
81 MBT(W)H10	5,190-15,580	1299	81	9	7690	9172
108 MBT(W)8	5,530-13,830	1383	108	12	6800	7800
108 MBT(W)10	6,920-17,300	1730	108	12	7700	9000
108 MBT(W)H8	5,530-16,590	1383	108	12	8480 **	9555 **
108 MBT(W)H10	6,920-20,760	1730	108	12	9320 **	10,580 **
144 MBWS8	7,380-18,450	1845	144	12	–	10,088
144 MBWS10	9,220-23,070	2307	144	12	–	10,559
162 MBT(W)8	8,310-20,780	2078	162	18	6600	9500
162 MBT(W)10	10,390-25,980	2598	162	18	9131	11,087
162 MBT(W)H8	8,310-24,930	2078	162	18	12,538	13,672
162 MBT(W)H10	10,390-31,170	2598	162	18	13,725	15,302
189 MBT(W)H8	9,690-29,070	2423	189	21	13,532	14,565
189 MBT(W)H10	12,110-36,340	3029	189	21	14,910	16,508
225 MBWS8	11,530-28,840	2884	225	15	–	14,460
225 MBWS10	14,420-36,060	3606	225	15	–	15,481
243 MBT(W)8	12,460-31,170	3117	243	27	8400	12,800
243 MBT(W)10	15,580-38,970	3897	243	27	12,605	14,687
297 MBT(W)H8	15,230-45,960	3808	297	33	20,173	21,390
297 MBT(W)H10	19,040-57,120	4760	297	33	21,924	24,172
324 MBT(W)8	16,620-41,560	4156	324	36	11,600	16,800
324 MBT(W)10	20,780-51,960	5196	324	36	16,034	19,467
324 MBT(W)H8	16,620-49,870	4156	324	36	21,570	21,755
324 MBT(W)H10	20,780-62,352	5196	324	36	23,215	25,495
324 MBWS8	16,620-41,560	4156	324	36	–	20,076
324 MBWS10	20,780-51,960	5196	324	36	–	20,154
405 MBT(W)8	20,780-51,950	5195	405	45	14,500	20,800
405 MBT(W)10	25,980-64,950	6495	405	45	19,201	23,985

* Based on clean filters.

** Two pyramid hoppers. Single outlet hopper also available.

Modular Baghouse

Dimensions & Specifications

Model	Dimensions (inches)						
	A	B		C	D		E
		MBT 48-in	MBT 72-in	MBT	MBW 48-in	MBW 72-in	MBW
36 MBT5	57.5	209.7	–	–	–	–	–
36 MBT6	57.5	221.7	–	–	–	–	–
36 MBT8	57.5	245.7	–	–	–	–	–
54 MBT6	57.5	244.2	–	–	–	–	–
54 MBT8	57.5	268.2	–	–	–	–	–
54 MBT10	57.5	292.2	–	–	–	–	–
54 MBT(W)H8	85.0	268.1	292.1	–	294.1	318.1	–
54 MBT(W)H10	85.0	292.1	316.1	–	342.1	366.1	–
81 MBT(W)8	85.0	268.2	292.2	–	294.1	318.1	–
81 MBT(W)10	85.0	292.2	316.2	–	342.1	366.1	–
81 MBT(W)H8	111.0	290.8	314.8	–	316.7	340.7	–
81 MBT(W)H10	111.0	314.8	338.8	–	364.7	388.7	–
108 MBT(W)8	111.0	290.8	314.8	–	316.7	340.7	–
108 MBT(W)10	111.0	314.8	338.8	–	364.7	388.7	–
108 MBT(W)H8	137.0	268.2*	292.2*	–	294.1	318.1	–
108 MBT(W)H10	137.0	292.2*	316.2*	–	342.1	366.1	–
144 MBWS8	111.0	–	–	–	316.6	340.6	–
144 MBWS10	111.0	–	–	–	364.6	388.6	–
162 MBT(W)8	163.0	268.2	292.2	292.3	294.1	318.1	318.4
162 MBT(W)10	163.0	292.2	316.2	316.2	342.1	366.1	366.1
162 MBT(W)H8	215.0	268.3	292.3	292.3	294.1	318.1	318.1
162 MBT(W)H10	215.0	292.3	316.3	316.3	342.1	366.1	366.1
189 MBT(W)H8	241.0	268.2	292.2	292.3	294.1	318.1	318.1
189 MBT(W)H10	241.0	292.2	316.2	316.2	342.1	366.1	366.1
225 MBWS8	137.0	–	–	–	339.1	363.1	–
225 MBWS10	137.0	–	–	–	387.1	411.1	–
243 MBT(W)8	241.0	268.2	292.2	292.2	294.1	318.1	318.1
243 MBT(W)10	241.0	292.2	316.2	316.2	342.1	366.1	366.1
297 MBT(W)H8	371.0	268.3	292.3	292.3	294.1	318.1	318.1
297 MBT(W)H10	371.0	292.3	316.3	316.3	342.1	366.1	366.1
324 MBT(W)8	319.0	268.2	292.2	292.2	294.1	318.1	318.1
324 MBT(W)10	319.0	292.2	316.2	316.2	342.1	366.1	366.1
324 MBT(W)H8	395.5	268.1	292.1	292.1	294.1	318.1	318.1
324 MBT(W)H10	395.5	292.1	316.1	316.1	342.1	366.1	366.1
324 MBWS8	163.0	–	–	–	320.6	344.6	–
324 MBWS10	163.0	–	–	–	417.3	441.3	–
405 MBT(W)8	397.0	268.2	292.2	292.2	294.1	318.1	318.1
405 MBT(W)10	397.0	292.2	316.2	316.2	342.1	366.1	366.1

* Two pyramid hoppers. Single outlet hopper also available.

Modular Baghouse

Dura-Life™ Filter Bag Technology

*Standard in All Donaldson Torit
Modular Baghouse Collectors*

Dura-Life — A technology breakthrough for bag users.

Polyester bags are produced with a needling process that creates larger pores where dust can embed into the fabric, inhibiting cleaning and reducing bag life. Dura-Life* bags are engineered with a unique hydroentanglement process that uses water to blend the fibers. This process provides a more uniform material with smaller pores, better surface loading, and better cleaning. These advantages provide twice the operating life before bags need to be replaced due to pressure drop. Longer life from Dura-Life bags lowers maintenance and operating costs and raises baghouse dust collection to a whole new level.

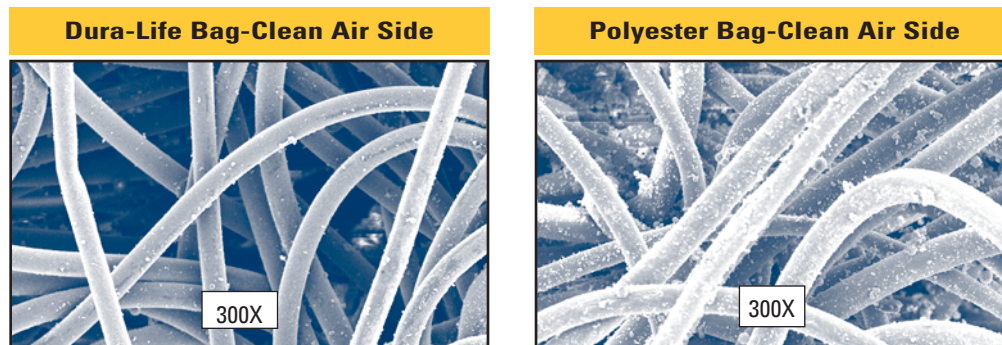

These photos were taken with a scanning electron microscope of bag media used in a collector that was filtering fly ash. The bags were removed after 2,700 hours of use. Air-to-media ratio was 4.5 to 1. Pressure drop was 6 in. on polyester bags and 2 in. on Dura-Life.

Dura-Life bags provide big benefits!

Dura-Life technology provides better surface loading and better pulse cleaning, resulting in:

- **Two to three times longer bag life**
- **Energy savings due to lower pressure drop**
- **Reduced replacement bag costs due to fewer bag changeouts**
- **Reduced maintenance and operating costs due to fewer bag changeouts**
- **30% fewer emissions based on EPA tests**



* Dura-Life bags are made with Durapex® filter media manufactured by Polymer Group, Inc.

Modular Baghouse

Standard Features & Equipment Options

	Standard	Optional
Collector Design		
Clean Air Plenum with Top-Bag Removal	X	
Heavy-Duty Ribbed Housing Construction	X	
All-Welded, Carbon Steel Design - 12 Gauge Minimum	X	
Heavy-Duty 10-Gauge Tubesheet	X	
Filter Cleaning System	X	
Service Railing with Kickplate per OSHA Specs (MBT)	X	
Bottom Bag Removal		X
High Temperature Construction		X
Stainless Steel Construction		X
Direct Drive Fans		X
Power Pack Transition for TBI Fans		X
Chamber and Exhaust Silencers		X
Damper Pack		X
Service Platform (MBW)		X
Bags & Cages		
Dura-Life Twice the Life Polyester Felt Snap-In Bags	X	
Galvanized Quick-Release Bag Cages	X	
Variety of Bag Media Options		X
Articulated Cages		X
Paint System		
Prime Coated Interior	X	
Blue Exterior Finish Coating Meets 250-Hour Salt Spray Corrosion Protection Test	X	
Hostile Environment Paint		X
Custom Colors		X

	Standard	Optional
Hopper Design		
60° Pyramid Hoppers	X	
Inlets with Deflector	X	
Trough Hopper with Multiple or Single Inlets	X	
Hopper Access Covers	X	
Inlet Transitions		X
Pyramid Hopper Cover with Flood Valve		X
Hopper Discharge		
Slide Gate Pack		X
55-Gallon Drum Pack		X
AN Rotary Valves and Transitions		X
Support Structure		
48" Clearance Leg Pack (pyramid hoppers)	X	
Stub Legs (trough hopper)	X	
72" Clearance Leg Pack		X
48" Clearance Ladder Pack		X
72" Clearance Ladder Pack (with cages)		X
Electrical Controls, Gauges and Enclosures		
Solenoid Valves in NEMA 4 Enclosure	X	
Magnehelic®* Gauge	X	
Control Timer in NEMA 4 Enclosure	X	
Solenoid Enclosure in NEMA 7 or 9		X
Photohelic® Gauge		X
Delta P Control Panel		X
Safety Features		
Sprinkler Access Ports	X	
Sprinkler Pack Assembly (wet or dry)		X
Explosion Vents		X
Warranty		
10-Year Warranty	X	

U.S. Patent 7,015,158

* Magnehelic and Photohelic are registered trademarks of Dwyer Instruments, Inc.

Information contained in this document is subject to change without notice.

Cleaner Air Worldwide

Better Technology



- 550 engineers worldwide
- More than 500 patents
- Broad range of innovative collectors and filters
- 100's of media formulations

Experience & Service



- Technical expertise and support
- Ready-to-ship filters and parts within 24 hours
- 1,000,000+ dust, fume, & mist collectors installed

Global Support



- Facilities in 35 countries
- 37 manufacturing plants and 11 distribution centers
- Sales offices worldwide



Donaldson®

Filtration Solutions

Donaldson Company, Inc.
Industrial Air Filtration
P.O. Box 1299
Minneapolis, MN
55440-1299 U.S.A.

Tel 800.365.1331
Tel 800.343.3639 (within Mexico)
dustmktg@mail.donaldson.com
www.donaldsontorit.com

**Call Donaldson Torit
to get Cleaner Air today
800-365-1331**



Printed in USA © Donaldson Company, 2004 Modular Baghouse 03-2007